

Ebeco Thermoflex Kit



*Monteringsanvisning
Installation instructions
Leggeanvisning
Asennusohje*

Installation instructions Ebeco Thermoflex Kit 300, 100

Carefully read through the entire installation instructions before start working.

General instructions

Thermoflex Kit is a complete heating cable system. It consists of a heating cable mat with a thin cable which is fitted to a mesh, thermostat EB-Therm and flexible conduit pipe. The system is primarily intended to heat tiled and natural stone floors. The diameter of the cable is only 4 mm. The system is connected at one end and the electrical and electromagnetic fields are negligible. The system must be laid in a layer of screed, minimum thickness 5 mm, on existing flooring such as concrete, chip- or plasterboard. The power is 120W/m².

- Check that length of the cable is correct and that the article number agrees with the table.
- The installation must be controlled by one of Ebeco's EB-Therm thermostats.
- The system must be connected to 230V via a 30mA Earth fault relay.
- **The heating cable must not be cut. Only the cold cable may be cut. The heating cable must not be crossed.**
- In wetrooms: Plan the layout so that the cold cable splice and the end termination do not end up in, or in adjacent to, the shower area, or under bathtubs, cupboards, etc.
- In wetrooms the heating cable should be laid underneath the sealing layer.
- The lowest temperature when fixing with adhesive tape is +18°C. The adhesive properties of the tape are reduced when the temperature of the floor is lower. Screed must be applied as soon as possible after laying the cable. If there is a delay before the screed is applied, press down the tape once more before applying the screed.
- The heating cable must not be laid under fixed fittings such as kitchen units, wardrobes, internal walls, etc., since this leads to overheating.
- Measure the insulation and resistance of the cable before and after laying, and after laying the floor. Enter the values in the test report in the guarantee certificate supplied. The 10-year guarantee is not valid without the signature of an authorized electrician.
- **Wait 4 weeks before switching on the heating, then increase the level of heating gradually.**
- Where the underfloor heating system is installed over a concrete floor laid directly on the ground, the heating should not be completely switched off during the summer.
- Do not cover the finished floor with thick, insulating carpets, "bean bags" etc., since this may cause local overheating and damage the floor.
- Affix the sign supplied at the electricity distribution board ("consumer unit"). At the same location there must also be a sketch of the cable layout; see the guarantee certificate.

Heating system laid on concrete, plaster- or chip-board

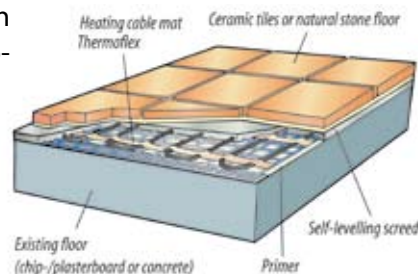

In addition to the Ebeco Thermoflex Kit you will need:

- Self-levelling screed (Uniplan E 89 605 43)
- Primer (E 89 605 49)
- Earth fault relay, if not already installed in the building (E 21 643 06)

Resistance value Ebeco Thermoflex Kit 300, 100

Tolerances $\pm 10\%$

THERMOFLEX KIT 300	THERMOFLEX KIT 100	CABLE MAT	POWER	SIZE	AREA	RESISTANCE
ART. NO.	ART. NO.	ART. NO.				
E 89 602 17	E 89 602 30	555 79	150 W	0,5 x 2,5 m	1,25 m ²	350 Ohm
E 89 602 18	E 89 602 32	555 80	200 W	0,5 x 3,4 m	1,7 m ²	266 Ohm
E 89 602 19	E 89 602 34	555 82	250 W	0,5 x 4,2 m	2,1 m ²	210 Ohm
E 89 602 20	E 89 602 36	555 84	340 W	0,5 x 5,4 m	2,7 m ²	157 Ohm
E 89 602 21	E 89 602 38	555 85	400 W	0,5 x 6,8 m	3,4 m ²	132 Ohm
E 89 602 22	E 89 602 40	555 86	480 W	0,5 x 7,8 m	3,9 m ²	111 Ohm
E 89 602 23	E 89 602 42	555 88	530 W	0,5 x 8,8 m	4,4 m ²	100 Ohm
E 89 602 24	E 89 602 44	555 90	640 W	0,5 x 10,8 m	5,4 m ²	83 Ohm
E 89 602 25	E 89 602 46	555 92	780 W	0,5 x 13,2 m	6,6 m ²	68 Ohm
E 89 602 26	E 89 602 48	555 94	940 W	0,5 x 15,8 m	7,9 m ²	56 Ohm
E 89 602 27		555 95	1170 W	0,5 x 19,2 m	9,6 m ²	45 Ohm
E 89 602 28	E 89 602 50	555 96	1380 W	0,5 x 23,0 m	11,5 m ²	38 Ohm
E 89 602 29		555 97	1700 W	0,5 x 28,0 m	14,0 m ²	31 Ohm
COMPLEMENTARY KIT - WITHOUT THERMOSTAT						
E 89 605 96	E 89 605 96	555 96	1380 W	0,5 x 23,0 m	11,5 m ²	38 Ohm

The underfloor heating system is a mains voltage installation and must therefore be installed and connected in accordance with the current regulations.

Substrate

Make sure that the floor is firm, does not sag and is free from dirt and old floorcovering material. Wood and chip-board floors over joists spaced at more than 30 cm need to be strengthened to prevent cracks from forming and tiles from coming loose. This applies even without underfloor heating.

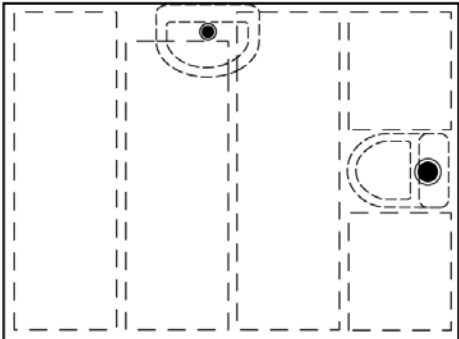

Figure 1

Installing

Make a drawing on the floor of how the mat/mats are to be positioned (Figure 1).

Plan the installation so that the cold cable joint and the end connection do not end up in the shower space.

Chase a groove in the floor for the flexible conduit where the floor sensor of the thermostat will be located. Place the floor sensor between two loops of the cable (Figure 2). Position the exposed end of the flexible conduit 30-50 cm into the room, where it will not be covered by carpets or furnishing. If the bend in the flexible conduit is too sharp it will be difficult to install the sensor. Be sure to make a smooth bend. Carefully seal the end of the flexible conduit with adhesive tape (Figure 2).

The tube at the side of the flexible conduit (see Figure 2) is intended for the cold cable. The cold cable splice must be in the floor. Make a recess in the floor so that the height of the joint is not greater than the thickness of the layer of screed.

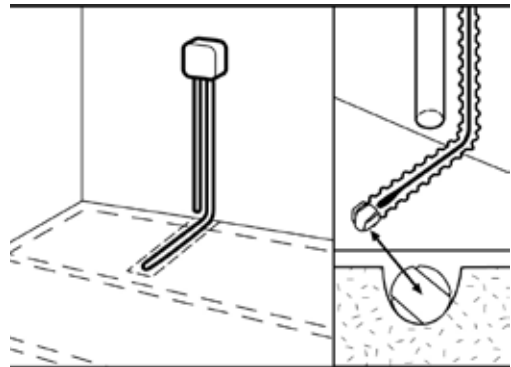

Figure 2

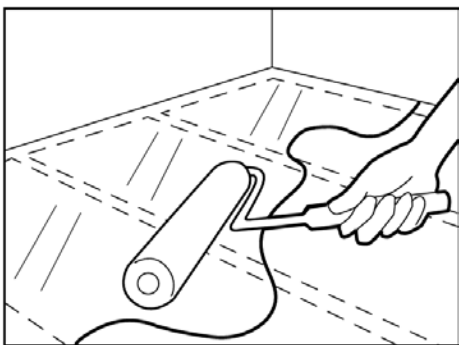

Figure 3

Prime the floor surface with Ebeco Primer (E 89 605 49) and let it dry (Figure 3).

Start fixing the Thermoflex in one corner. If the cold cable is not long enough to reach the connection point/thermostat, you can cut the matting into as many sections as needed and install the cable along the wall to come closer. The cable splice should be inset in the floor. The matting must not be laid under fixed furnishings, toilets and the like. Note the position of the toilet's screws. Remove approx. 30 cm of the protective paper from the tape (all 4 pieces of tapes), align the matting and press down the first 30 cm of the matting. Hold the protective paper from all the tapes. Carefully pull the protective paper. The matting will then roll out and bond to the floor. Press the tape against the floor (Figure 4).

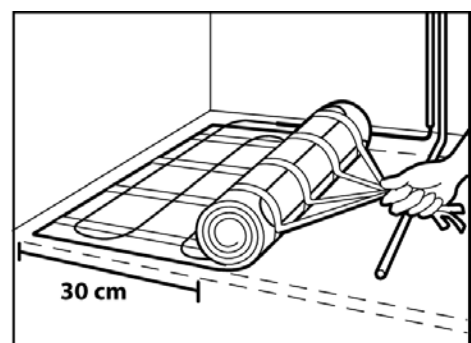

Figure 4

Roll out the matting to the opposite wall. Cut the mesh without damaging the cable. Loosen the protective paper and roll the matting back again. The cables should not be closer than 5 cm to each other when cutting the mesh (Figures 5 and 6).

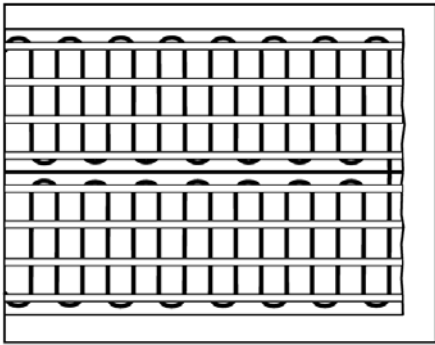

Figure 5

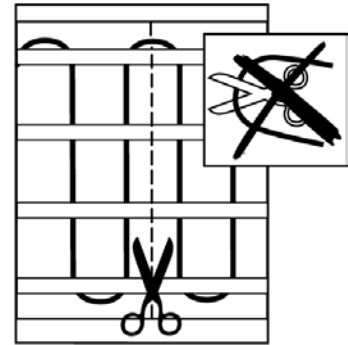

Figure 6

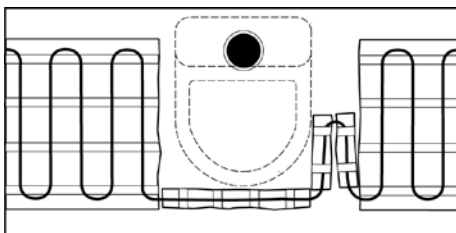

Figure 7

Cut and release a piece of mesh and go round toilets and the like. Cut another piece of mesh and place the cable as shown in the figure. Now, the matting can be rolled out at the right side, otherwise the installation will be more difficult (Figure 7).

To make sure that the tape sticks properly, it shall be pressed down with hands or feet. This is especially important on rough surface, such as concrete. To protect the cable, wear soft-soled shoes or go barefoot. If you do not apply the filler immediately after taping the cable, **press the tape down** once more just before applying the screed (Figures 8 and 9).

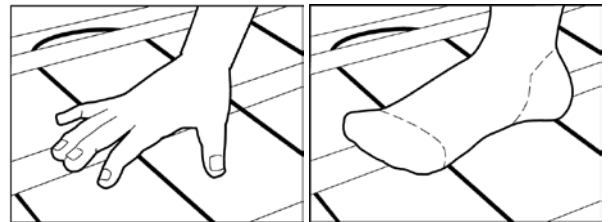

Figure 8

Figure 9

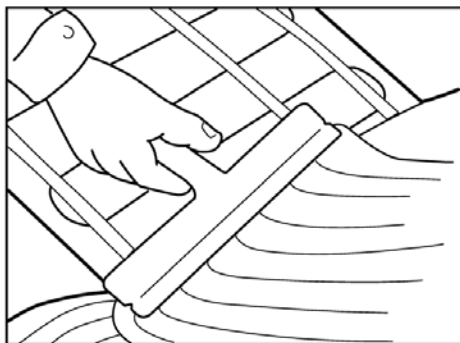

Figure 10

To further improve the adhesive qualities the floor can be primed once more using undiluted primer, the matting will then bond very well to the floor. The mesh can also be stapled to plasterboards.

The insulation and resistance of the matting should now be measured. The values should be noted in the test protocol. The position of the matting should be documented on a sketch or photograph and be kept by the electricity distribution board. Apply Ebeco Uniplan screed (E 89 605 43) or equivalent to the floor (Figure 10).

Measure the insulation and resistance of the cable again, to check that the cable was not damaged when the screed was applied. Lay the floor tiles in accordance with the manufacturer's instructions. Use flexible tile adhesive and grout (Figure 11).

Measure the insulation and resistance of the cable once more and enter the readings in the test report. For floor design, filling, sealing layer, tiling, grouting, etc., see the current trade rules and the supplier's instructions.

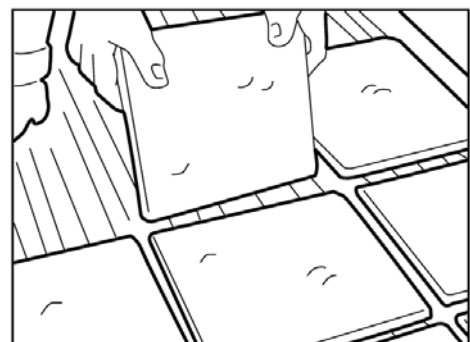

Figure 11

Guarantee Certificate

EN

Cable Kit, Thermoflex Kit, Foil Kit and Multiflex 20*

Ebeco AB provides a 10 year guarantee for defective materials in Cable Kit, Thermoflex Kit, Foil Kit, Multiflex 20-cable* and EB-Therm thermostats, henceforth called "the Products".

The guarantee only becomes valid under condition that the Products are installed by a qualified electrician according to the applicable regulations and in accordance with installation instructions issued by Ebeco. This guarantee certificate, including test record below, must be completed in its entirety and, along with the materials specification or invoice, must be signed by the electrician who carried out the installation. Furthermore, there must be photographs/sketches that show the Products in their entirety after laying but before covering.

If defects to materials should arise in the Products during the guarantee period, Ebeco AB undertakes to repair or alternatively replace the Products at no cost to the purchaser.

Ebeco AB also undertakes to restore the floor to its original condition after the repair or replacement has been completed. In order to be able to remedy the fault the purchaser must have saved or have access to 1 m² of the existing floor material. In wet rooms Ebeco AB reserves the right to lay a new cable and a new tiled floor over the top of the existing one to avoid breaking the sealing layer. For thermostats, with defects that occur after 3 years Ebeco AB supplies a new thermostat.

*Applies only under condition that the product is installed indoors, together with Ebeco's control system.

The guarantee does not apply to installations that have been carried out by an unqualified electrician or alternatively if an unqualified electrician has carried out modifications or repairs. Nor does the guarantee apply if the defect has arisen as a result of using incorrect materials and floor construction or as a result of incorrect installation. Nor is damage covered that is a result of vandalism, fire, lightning, water damage or damage caused by negligence, abnormal usage or as a result of an accident.

In the event of a material defect arising that is covered by the guarantee Ebeco AB must be notified.

In the event of the guarantee being invoked, this guarantee certificate with accompanying invoice of installation, material specification plus completed and signed test record must be presented.

EBECO AB
Ebbe Larsson, MD

Electrical installation carried out by:

according to enclosed materials specification.

Date: -----

Signature: -----

Test record Cable Kit, Thermoflex Kit & Multiflex 20 Min. Insulation value 10 Mohm.

PRODUCT:	Before laying		After fixing		After floor covering	
	RESISTANCE VALUE	INSULATION VALUE	RESISTANCE VALUE	INSULATION VALUE	RESISTANCE VALUE	INSULATION VALUE
E-NO.: Cable / Mat 1						

Test Report Foil Kit

Tolerance of resistance values: -5 to +10%. Min. Insulation value 10 Mohm.

	Before laying	After fixing		After floor covering	
	Theoretical RESISTANCE-VALUE Ohm	RESISTANCE-VALUE Ohm	INSULATION-VALUE Mohm	RESISTANCE-VALUE Ohm	INSULATION-VALUE Mohm
E-NO: Installed length (m):					
E-NO: Installed length (m):					
E-NO: Installed length (m):					

230 V, 65W/m ² , width: 43 cm
$\frac{2034,6}{\text{length (m)}} = \text{theoretical resistance value}$

Mark your drawing with the respective number

PRODUCT:

- Cable Kit 50
- Cable Kit 200
- Cable Kit 300
- Thermoflex Kit 100
- Thermoflex Kit 300

- Foil Kit
- Multiflex 20*

*in combination with:

- EB-Therm 50
- EB-Therm 100
- EB-Therm 200
- EB-Therm 300
- EB-Therm 350

IS INSTALLED IN THE FOLLOWING ROOMS:

- Hall
- Kitchen
- Wet room
- Living room
- Bedroom
- Conservatory
- Other.....

If the floor surface is to be replaced, the new material must be suitable for underfloor heating. Contact your flooring supplier for information. Do not position insulating material or floor fixtures on surfaces where there is underfloor heating. This reduces heat transfer into the room and produces a higher temperature in the floor.

Length/Size

Power/Voltage

A detailed sketch of the terminations and splices in the cables/mats/foil, and the exact positioning of any connection boxes must be entered above. In addition, take a photographic record of the laying process. Mark the sketch with the respective E-number from the test record. This sheet or a copy of it should be displayed beside the fuse panel. Further requirements for information for the end user are available in Swedish standard SS 436 47 53.